

TWG3246-370CA 32×46mm worm gearbox plus 370 permanent magnet DC motor

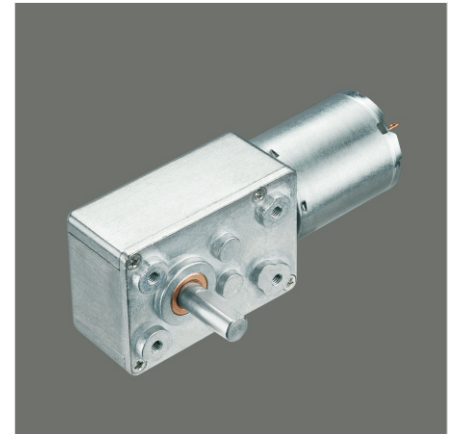

模数 Module	0.5/0.6		
额定负载 Rated torque (kg.cm)	8.0 kg.cm max		
瞬间允许力矩 Max momentary tolerance torque (kg.cm)	15.0 kg.cm max		
减速比 Reduction ratio	1/70、1/146	1/483、1/563	1/1020、1/1313
	1/188、1/233	1/700、1/900	1/1688、1/2100
	1/300		1/2700
齿轮箱减速级数 Number of gear stages	3	4	5
减速箱长度 Gearbox length L (mm)	46.0		

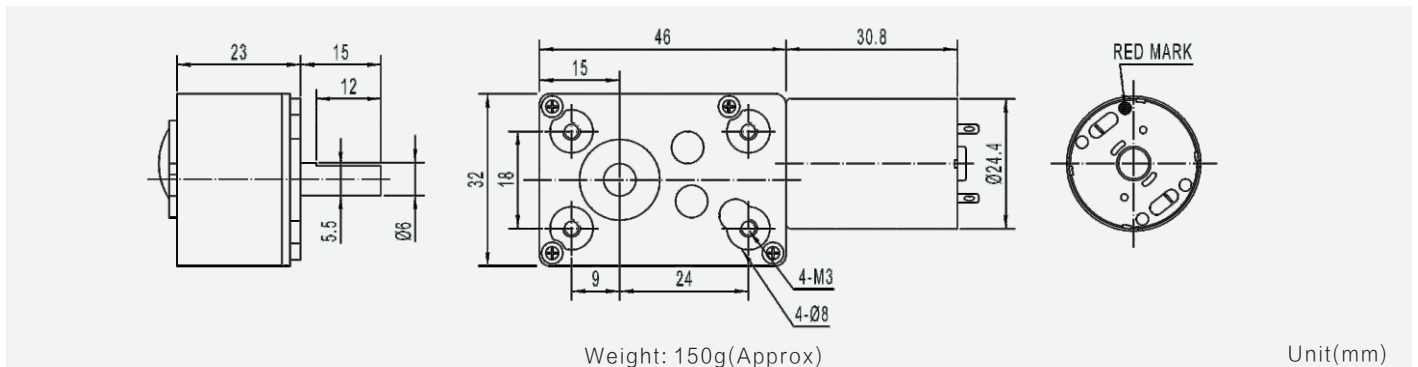

减速电机技术参数 Gear Motor Technical Data

	146	188	300	438	563	700	900	1020	1313	1688
6.0V										
减速比 Reduction ratio	146	188	300	438	563	700	900	1020	1313	1688
空载转速 No-load speed (rpm)	38	30	19	12	10	8	6	5	4	3
负载转速 Rated speed (rpm)	32	25	16	10	8	6	5	4	3	3
负载力矩 Rated torque (kg.cm)	2.0	2.5	4.0	5.0	7.0	8.0	8.0	8.0	8.0	8.0
12.0V										
空载转速 No-load speed (rpm)	38	30	19	12	10	8	6	5	4	3
负载转速 Rated speed (rpm)	32	25	16	10	8	6	5	4	3	3
负载力矩 Rated torque (kg.cm)	2.0	2.5	4.0	5.0	7.0	8.0	8.0	8.0	8.0	8.0

单电机技术参数 Motor Technical Data

电机型号 Motor model	额定电压 Rated voltage	无负荷 No-load		额定 Rated			堵转 Stall		
		转速 Speed	电流 Current	转速 Speed	力矩 Torque	电流 Current	功率 Power	力矩 Torque	电流 Current
	VDC	r/min	mA	r/min	g.cm	mA	W	g.cm	A
TRK-370CA-22170	6.0	5600	50	4870	25	320	1.25	191	2.1
TRK-370CA-15360	12.0	5600	25	4850	25	170	1.24	186	1.1

