

TWG1220-N30VA

12x20mm worm gearbox plus N30 permanent magnet DC motor

模数 Module	0.2/0.3		
额定负载 Rated torque (kg.cm)	1kg.cm max		
瞬间允许力矩 Max momentary tolerance torque (kg.cm)	2.0 kg.cm max		
减速比 Reduction ratio	1/40, 1/80 1/95, 1/190	1/219, 1/438	1/504, 1/1007
齿轮箱减速级数 Number of gear stages	4	5	6
减速箱长度 Gearbox length L (mm)	20.0		

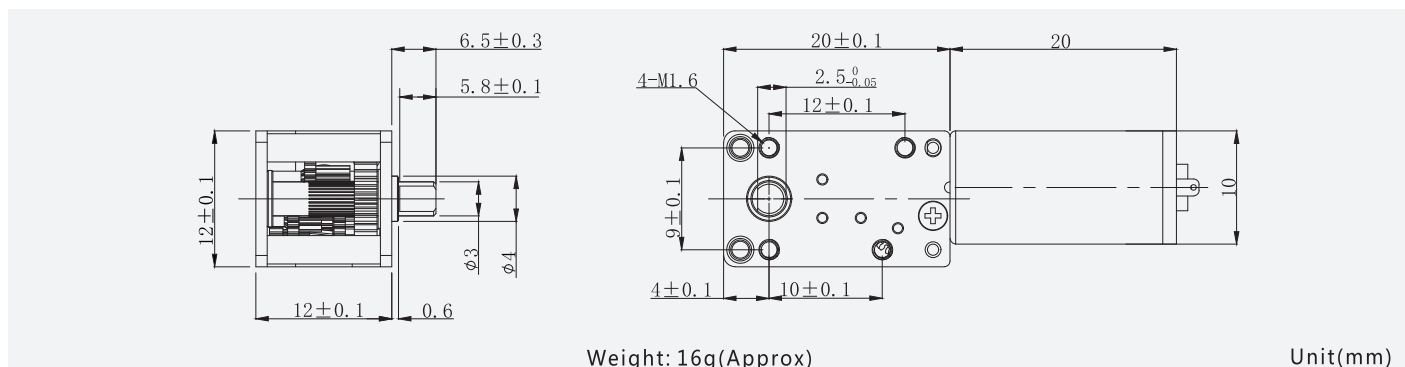

减速电机技术参数 Gear Motor Technical Data

		40	80	95	190	219	438	504	1007
6.0V	减速比 Reduction ratio	40	80	95	190	219	438	504	1007
	空载转速 No-load speed (rpm)	312	156	130	65	57	28	25	12
	负载转速 Rated speed (rpm)	265	132	112	56	48	24	21	10
12.0V	空载转速 No-load speed (rpm)	312	156	130	65	57	28	25	12
	负载转速 Rated speed (rpm)	260	130	109	55	47	24	20	10
	负载力矩 Rated torque (kg.cm)	0.035	0.07	0.085	0.17	0.2	0.4	0.5	1

单电机技术参数 Motor Technical Data

电机型号 Motor model	额定电压 Rated voltage	无负荷 No-load		额定 Rated				堵转 Stall	
		转速 Speed	电流 Current	转速 Speed	力矩 Torque	电流 Current	功率 Power	力矩 Torque	电流 Current
	VDC	r/min	mA	r/min	g.cm	mA	W	g.cm	A
TFF-N30VA-09190	6.0	12500	25	10600	3.0	98	0.33	20	0.50
TFF-N30VA-06350	12.0	12500	12	10400	3.0	50	0.32	18	0.25

