

TEC56100

56mm brushless motor

接线方式 B或C	Connection Mode B & C		
正反转功能	Clockwise Rotation/Counter Clockwise Rotation		
信号输出功能	FG Signal		
脉宽调速功能	PWM Control		
锁定保护	Locked Rotor Protection		
最大功率	/	Power	/
	50W(外置驱动)		50W(External Drive)
电机寿命	/	Life Expectancy	/
	约5000H(滚珠轴承)		~5000H(Ball Bearing)

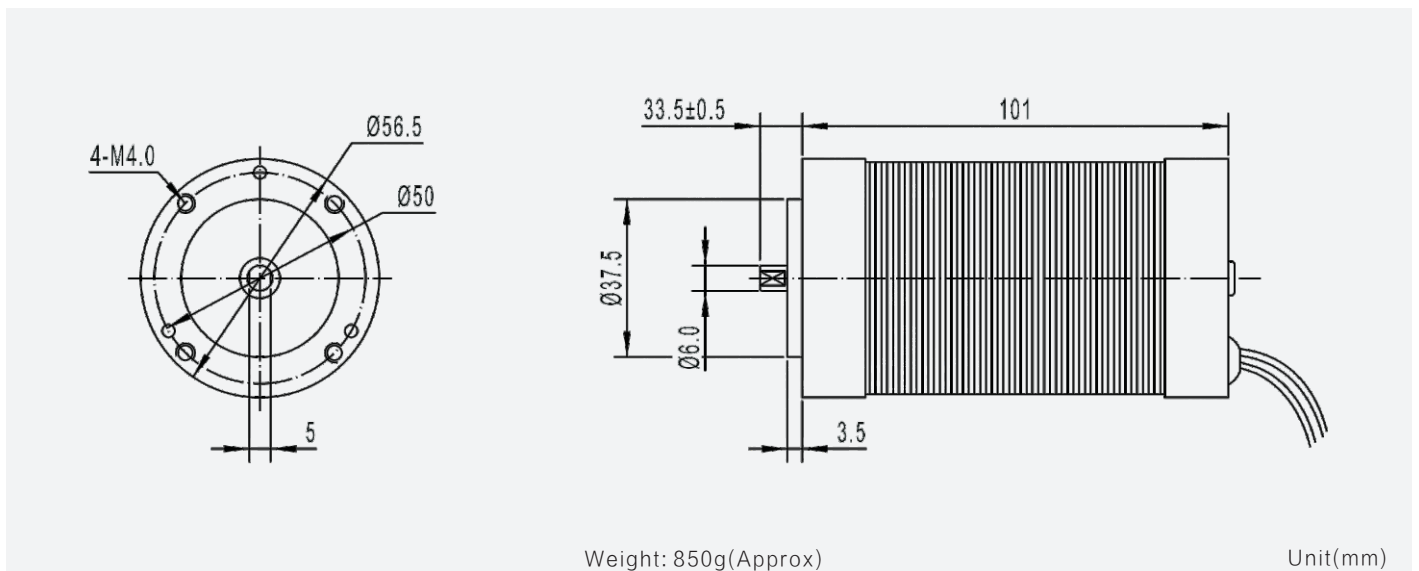

单电机技术参数 Motor Technical Data

电机型号 Motor model	额定电压 Rated voltage	无负荷 No-load		额定 Rated			堵转 Stall		
		转速 Speed	电流 Current	转速 Speed	力矩 Torque	电流 Current	功率 Power	力矩 Torque	电流 Current
	VDC	r/min	mA	r/min	g.cm	mA	W	g.cm	A
TEC56100-1235	12.0	3500	600	3050	400	1900	12.5	3200	4.5
TEC56100-2435	24.0	3500	300	3050	400	1000	12.5	3200	4.5

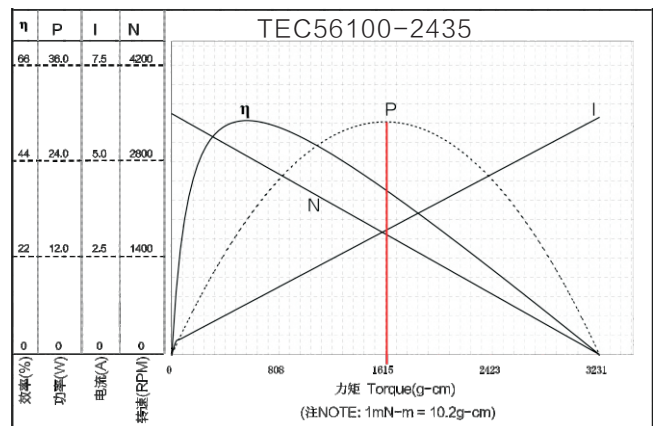
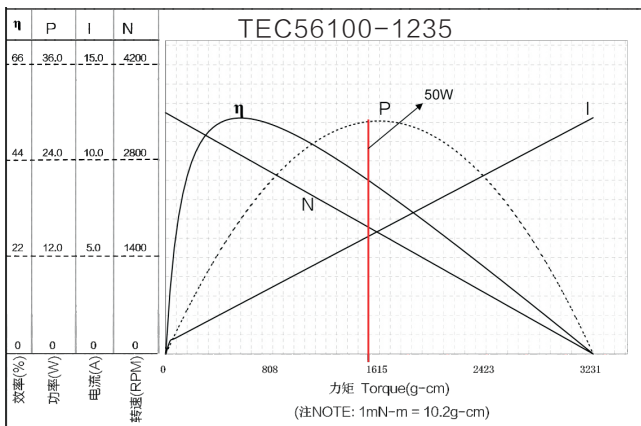

备注: 红线左侧为电机可以连续工作区域NOTE: the left side of red line area can continuous work