

GMP60-TEC56100

60mm planetary gearbox plus 60mm brushless motor

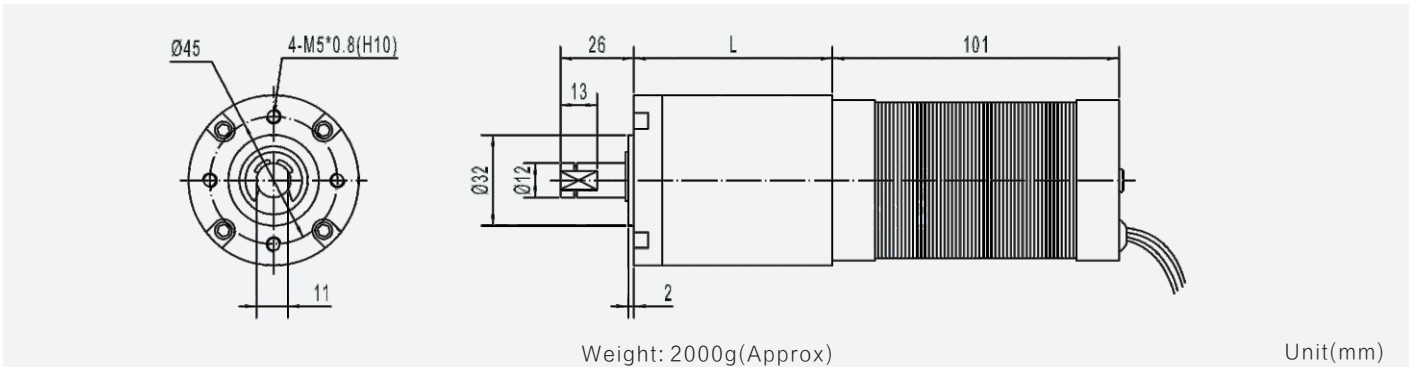

模数 Module	1.0			
额定负载 Rated torque (kg.cm)	200 kg.cm max			
瞬间允许力矩 Max momentary tolerance torque (kg.cm)	400 kg.cm max			
减速比 Reduction ratio	1/4	1/13 1/15 1/18	1/47, 1/55 1/65, 1/77	1/168, 1/198 1/234, 1/276 1/326
齿轮箱减速级数 Number of gear stages	1	2	3	4
减速箱长度 L (mm)	36	48	59	70



减速电机技术参数 Gear Motor Technical Data

12.0V	减速比 Reduction ratio	4	13	18	47	55	77	168	198	326
	空载转速 No-load speed (rpm)	870	260	190	72	62	45	20	18	11
	负载转速 Rated speed (rpm)	760	230	170	65	55	40	18	15	9
	负载力矩 Rated torque (kg.cm)	1.4	4.2	5.8	14	16	23	47	55	90
24.0V	空载转速 No-load speed (rpm)	870	260	190	72	62	45	20	18	11
	负载转速 Rated speed (rpm)	760	230	170	65	55	40	18	15	9
	负载力矩 Rated torque (kg.cm)	1.4	4.2	5.8	14	16	23	47	55	90

单电机技术参数 Motor Technical Data

电机型号 Motor model	额定电压 Rated voltage VDC	无负荷 No-load		额定 Rated			堵转 Stall		
		转速 Speed r/min	电流 Current mA	转速 Speed r/min	力矩 Torque g.cm	电流 Current mA	功率 Power W	力矩 Torque g.cm	电流 Current A
TEC56100-1235	12.0	3500	600	3050	400	1900	12.5	3200	4.5
TEC56100-2435	24.0	3500	300	3050	400	1000	12.5	3200	4.5

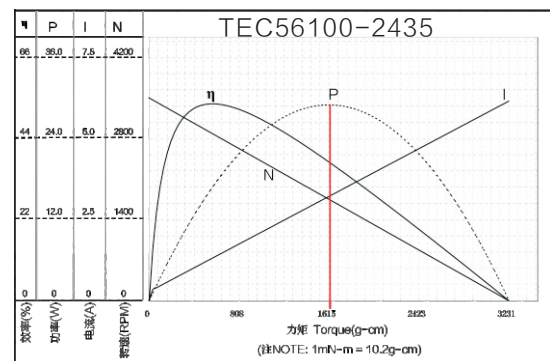
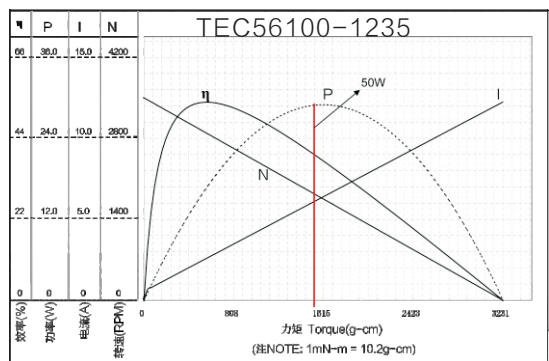

备注：红线左侧为电机可以连续工作区域NOTE: the left side of red line area can continuous work