

GMP60-6097/60127

60mm planetary gearbox plus 60mm DC motor

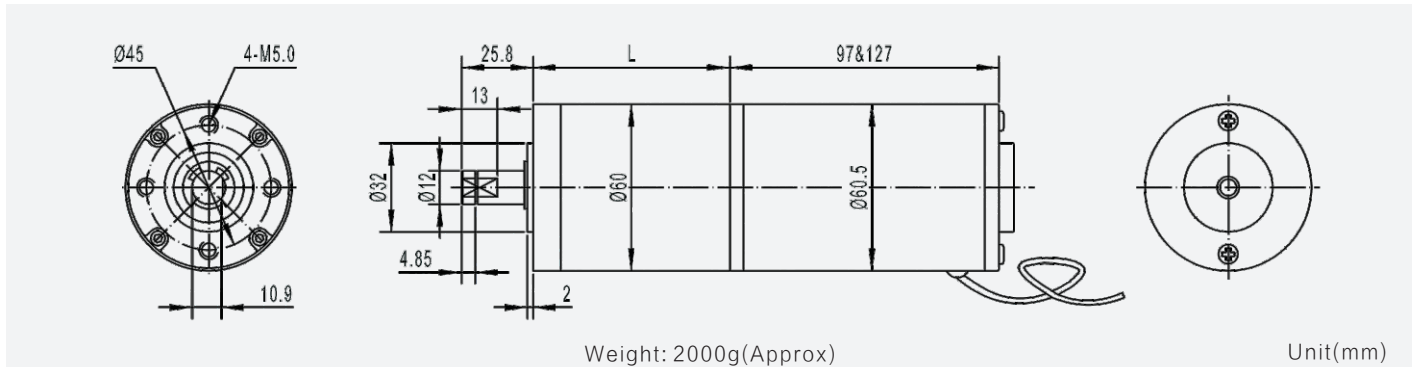

模数 Module	1.0			
额定负载 Rated torque (kg.cm)	200 kg.cm max			
瞬间允许力矩 Max momentary tolerance torque (kg.cm)	400 kg.cm max			
减速比 Reduction ratio	1/4	1/13 1/15 1/18	1/47, 1/55 1/65, 1/77	1/168, 1/198 1/234, 1/276 1/326
齿轮箱减速级数 Number of gear stages	1	2	3	4
减速箱长度 L (mm)	36	48	59	70



减速电机技术参数 Gear Motor Technical Data

24.0V	减速比 Reduction ratio	4	13	18	47	55	77	168	198	326
24.0V	空载转速 No-load speed (rpm)	690	190	140	53	45	32	15	13	8
	负载转速 Rated speed (rpm)	550	150	110	42	36	26	12	10	6
	负载力矩 Rated torque (kg.cm)	5	15	21	50	55	80	150	180	200
24.0V	空载转速 No-load speed (rpm)	1660	460	330	95	110	78	35	30	18
	负载转速 Rated speed (rpm)	1250	350	250	70	80	58	25	22	15
	负载力矩 Rated torque (kg.cm)	10	30	42	100	110	160	200	200	200

单电机技术参数 Motor Technical Data

电机型号 Motor model	额定电压 Rated voltage	无负荷 No-load		额定 Rated			堵转 Stall		
		转速 Speed	电流 Current	转速 Speed	力矩 Torque	电流 Current	功率 Power	力矩 Torque	电流 Current
	VDC	r/min	mA	r/min	g.cm	mA	W	g.cm	A
TRK-6097-2425	24.0	2500	250	2000	1500	1800	30	7500	8.0
TRK-60127-2460	24.0	6000	750	4500	3000	8200	138	12000	31

