

GMP42-4278

42mm gearbox plus 4278 permanent magnet DC motor

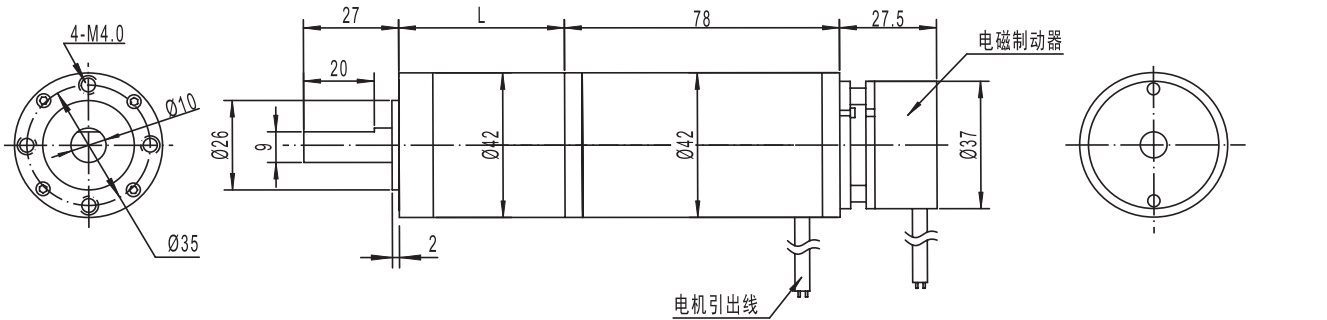

模数 Module	0.6			
额定负载 Rated torque (kg.cm)	60.0kg.cm max			
瞬间允许力矩 Max momentary tolerance torque (kg.cm)	120.0kg.cm max			
减速比 Reduction ratio	1/4	1/14 1/19 1/27	1/51、1/71 1/100、1/139	1/189、1/264 1/369、1/516 1/720
齿轮箱减速级数 Number of gear stages	1	2	3	4
减速箱长度 Gearbox length L (mm)	25.5	36	46	56



Weight:750(Approx)

Unit(mm)

减速电机技术参数 Gear Motor Technical Data

减速比 Reduction ratio		4	19	51	100	139	189	264	369	516	720
24.0V	空载转速 No-load speed (rpm)	750	155	55	28	20	15	11	8	5	4
	负载转速 Rated speed (rpm)	630	125	48	24	17	12	9	7	4	3
	负载力矩 Rated torque (kg.cm)	1.5	6.5	15	30	40	50	60	60	60	60

单电机技术参数 Motor Technical Data

电机型号 Motor model	额定电压 Rated voltage	无负荷 No-load			额定 Rated			堵转 Stall	
		转速 Speed	电流 Current	功率 Power	转速 Speed	力矩 Torque	电流 Current	力矩 Torque	电流 Current
	VDC	r/min	mA	W	r/min	g.cm	mA	g.cm	A
TRS-4278-2430	24	3000	170	11.3	2460	450	790	2500	3.6

