

GMP36-555PM 36mm planetary gearbox plus 555permanent magnet DC motor

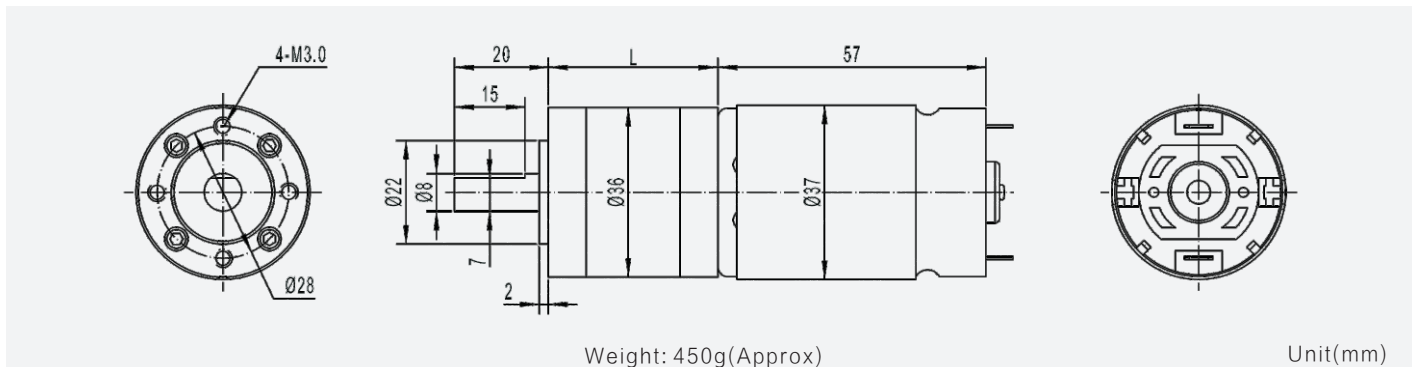

模数 Module	0.5			
额定负载 Rated torque (kg.cm)	30.0 kg.cm max			
瞬间允许力矩 Max momentary tolerance torque (kg.cm)	60.0 kg.cm max			
减速比 Reduction ratio	1/4	1/14 1/19 1/27	1/51, 1/71 1/100, 1/139	1/189, 1/264 1/369, 1/516 1/720
齿轮箱减速级数 Number of gear stages	1	2	3	4
减速箱长度 L (mm)	26	33.5	40.5	47.5



减速电机技术参数 Gear Motor Technical Data

12.0V	减速比 Reduction ratio	4	19	51	100	139	189	264	369	516	720
	空载转速 No-load speed (rpm)	1200	250	95	48	35	25	19	13	10	7
负载转速 Rated speed (rpm)	1100	230	85	45	31	23	16	12	9	6	
负载力矩 Rated torque (kg.cm)	0.6	3.0	6.0	12	15	21	26	30	30	30	
24.0V	空载转速 No-load speed (rpm)	980	200	75	38	28	21	15	10	8	6
	负载转速 Rated speed (rpm)	750	150	60	30	21	16	13	9	7	5
	负载力矩 Rated torque (kg.cm)	0.6	3.0	6.0	12	15	21	26	30	30	30

单电机技术参数 Motor Technical Data

电机型号 Motor model	额定电压 Rated voltage	无负荷 No-load		额定 Rated			堵转 Stall		
		转速 Speed	电流 Current	转速 Speed	力矩 Torque	电流 Current	功率 Power	力矩 Torque	电流 Current
TRS-555PM-1250	12.0	5000	250	4400	200	1700	9.0	1640	12.6
TRS-555PM-2440	24.0	4000	150	3150	200	700	6.4	1000	2.7

