

GMP36-35BY

36mm planetary gearbox plus 35mm stepper motor

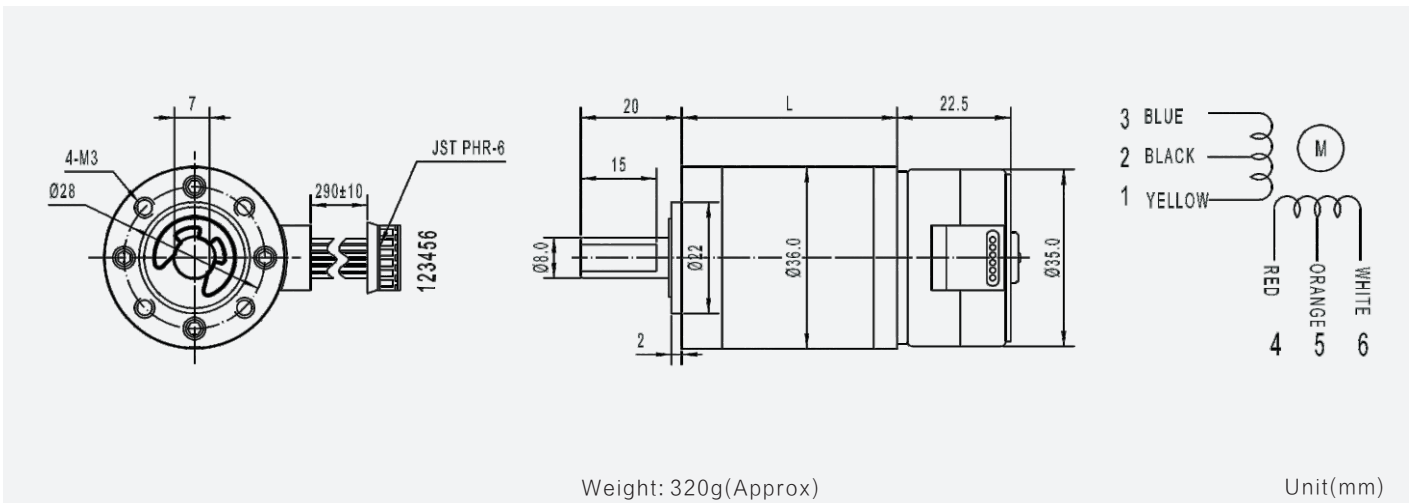

模数 Module	0.5			
额定负载 Rated torque (kg.cm)	30.0 kg.cm max			
瞬间允许力矩 Max momentary tolerance torque (kg.cm)	60.0 kg.cm max			
减速比 Reduction ratio	1/4	1/14 1/19 1/27	1/51, 1/71 1/100, 1/139	1/189, 1/264 1/369, 1/516 1/720
齿轮箱减速级数 Number of gear stages	1	2	3	4
减速箱长度 L (mm)	26	33.5	40.5	47.5



单电机技术参数 Motor Technical Data

电机型号 Motor model	额定电压 Rated voltage	相数 No. of phase	步进角 Step angle	绕线电阻 Resistance	电流 Current	电感 Inductance	自定位力矩 Detent torque	保持力矩 Holding torque	牵入频率 Pull in rate
	VDC			Ω	mA	mH	g.cm	g.cm	pps
TS-35BY-001	12.0	4	7.5°	60	200		60	130	350

