

GMP10-10BY

10mm planetary gearbox plus 10mm stepper motor

模数 Module	0.2			
额定负载 Rated torque (kg.cm)	0.5 kg.cm max			
瞬间允许力矩 Max momentary tolerance torque (kg.cm)	1.0 kg.cm max			
减速比 Reduction ratio	1/16	1/64	1/256	1/1024
齿轮箱减速级数 Number of gear stages	2	3	4	5
减速箱长度 Gearbox length L (mm)	12	15	18	21

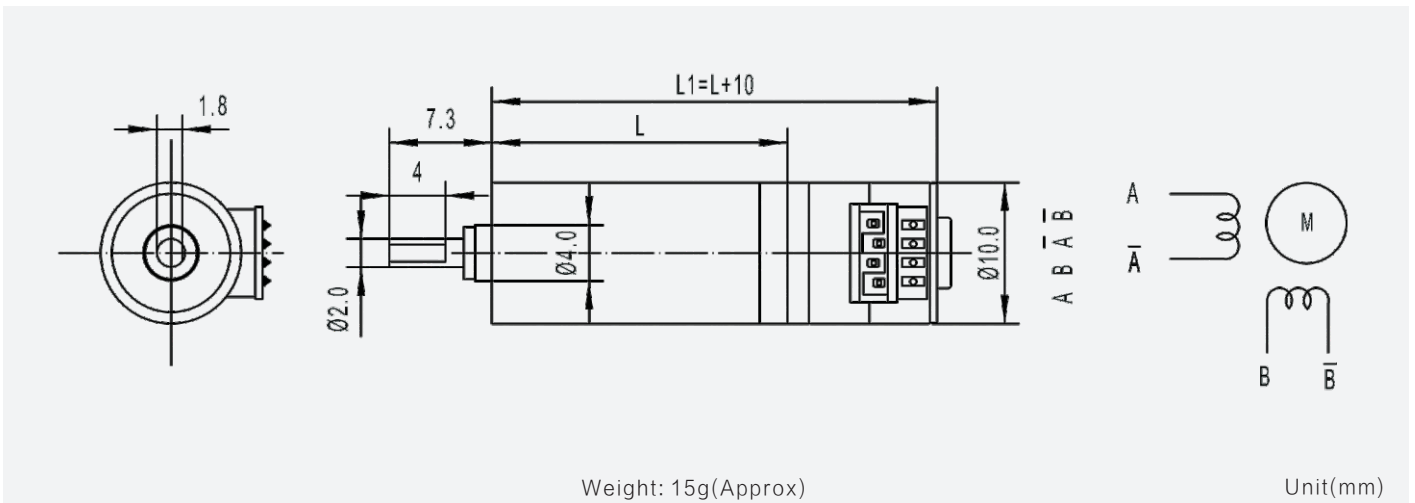

单电机技术参数 Motor Technical Data

电机型号 Motor model	额定电压 Rated voltage	相数 No. of phase	步进角 Step angle	绕线电阻 Resistance	电流 Current	电感 Inductance	自定位力矩 Detent torque	保持力矩 Holding torque	牵入频率 Pull in rate
	VDC			Ω	mA	mH	g.cm	g.cm	pps
TS-10BY-001	3.3	2	18°	12.2	270			5	1200

