

GM37T-555PM 37mm gearbox plus 555 permanent magnet DC motor

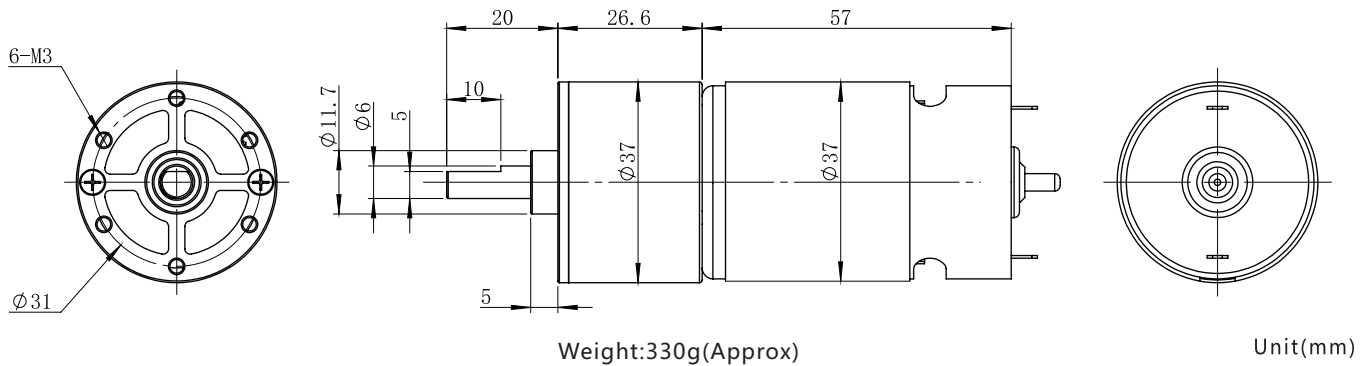

模数 Module	0.5/0.6		
额定负载 Rated torque (kg.cm)	10kg.cm max		
瞬间允许力矩 Max momentary tolerance torque (kg.cm)	20kg.cm max		
减速比 Reduction ratio	1/29 1/49	1/67 1/98 1/126 1/145	1/202 1/294 1/378 1/635
齿轮箱减速级数 Number of gear stages	4	5	6
减速箱长度 Gearbox length L (mm)	26.6		



减速电机技术参数 Gear Motor Technical Data

减速比 Reduction ratio		29	49	67	98	126	145	202	294	378	635
12.0V	空载转速 No-load speed (rpm)	172	102	75	51	40	34	25	17	13	8
	负载转速 Rated speed (rpm)	148	88	64	44	34	30	21	15	11	7
	负载力矩 Rated torque (kg.cm)	3.8	6.4	8.0	10	10	10	10	10	10	10
24.0V	空载转速 No-load speed (rpm)	138	82	60	41	32	28	20	14	11	6
	负载转速 Rated speed (rpm)	110	65	48	33	25	22	16	11	8	5
	负载力矩 Rated torque (kg.cm)	3.8	6.4	8.0	10	10	10	10	10	10	10

单电机技术参数 Motor Technical Data

电机型号 Motor model	额定电压 Rated voltage	无负荷 No-load		额定 Rated			堵转 Stall		
		转速 Speed	电流 Current	转速 Speed	力矩 Torque	电流 Current	功率 Power	力矩 Torque	电流 Current
	VDC	r/min	mA	r/min	g.cm	mA	W	g.cm	A
TRS-555PM-1250	12	5000	250	4300	200	1400	8.8	1430	8.5
TRS-555PM-2440	24	4000	150	3200	200	800	6.6	1000	3.5

