

GM37-520TB

37mm gearbox plus 520 permanent magnet DC motor

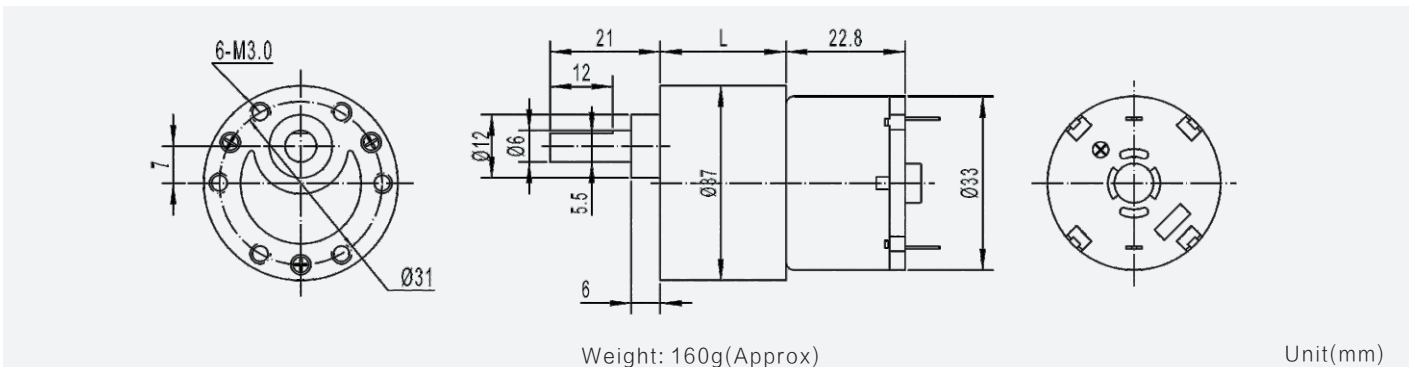

模数 Module	0.5/0.6				
额定负载 Rated torque (kg.cm)	8.0 kg.cm max				
瞬间允许力矩 Max momentary tolerance torque (kg.cm)	15.0 kg.cm max				
减速比 Reduction ratio	1/6 1/10	1/19 1/30	1/44 1/56 1/90	1/131 1/169 1/270	1/506 1/810
齿轮箱减速级数 Number of gear stages	2	3	4	5	6
减速箱长度 Gearbox length L (mm)	19	21.5	24	26.5	29



减速电机技术参数 Gear Motor Technical Data

电压 Voltage	减速比 Reduction ratio	性能 Performance											
		空载转速 No-load speed (rpm)	负载转速 Rated speed (rpm)	负载力矩 Rated torque (kg.cm)	空载转速 No-load speed (rpm)	负载转速 Rated speed (rpm)	负载力矩 Rated torque (kg.cm)	空载转速 No-load speed (rpm)	负载转速 Rated speed (rpm)	负载力矩 Rated torque (kg.cm)	空载转速 No-load speed (rpm)	负载转速 Rated speed (rpm)	负载力矩 Rated torque (kg.cm)
12.0V	6	750	690	0.1	700	640	0.1	700	640	0.1	700	640	0.1
	10	480	420	0.2	465	395	0.2	465	395	0.2	465	395	0.2
	19	250	225	0.3	240	205	0.3	240	205	0.3	240	205	0.3
24.0V	30	160	140	0.4	150	130	0.4	150	130	0.4	150	130	0.4
	56	88	77	0.8	80	70	0.8	80	70	0.8	80	70	0.8
	90	55	48	1.2	50	44	1.2	50	44	1.2	50	44	1.2
24.0V	169	30	25	2.0	27	23	2.0	27	23	2.0	27	23	2.0
	270	18	16	3.2	17	15	3.2	17	15	3.2	17	15	3.2
	506	10	8	5.0	9	7	5.0	9	7	5.0	9	7	5.0
24.0V	810	6	5	8.0	6	5	8.0	6	5	8.0	6	5	8.0

单电机技术参数 Motor Technical Data

电机型号 Motor model	额定电压 Rated voltage	无负荷 No-load		额定 Rated			堵转 Stall		
		转速 Speed	电流 Current	转速 Speed	力矩 Torque	电流 Current	力矩 Torque	电流 Current	
	VDC	r/min	mA	r/min	g.cm	mA	W	g.cm	A
TRK-520TB-1250	12.0	5000	20	4300	20	120	0.88	140	0.9
TRK-520TB-2446	24.0	4650	12	3950	20	55	0.82	125	0.32

