

# GM25-320SH

25mm gearbox plus 320 permanent magnet DC motor

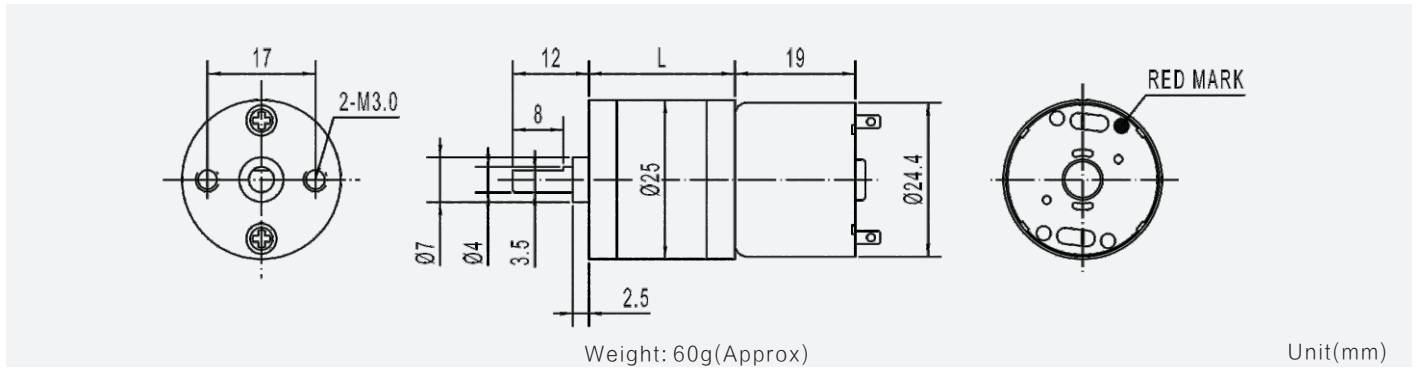

模数 Module	0.4						
额定负载 Rated torque (kg.cm)	3.0 kg.cm max						
瞬间允许力矩 Max momentary tolerance torque (kg.cm)	6.0 kg.cm max						
减速比 Reduction ratio	1/4.2 1/4.4	1/9.3 1/10	1/20 1/21	1/34 1/45 1/47	1/75 1/78 1/99 1/103	1/130 1/165 1/172 1/217 1/227	1/362 1/378 1/478 1/499
齿轮箱减速级数 Number of gear stages	2	3	4	5	6	7	8
减速箱长度 Gearbox length L (mm)	17	19	21	23	25	27	



## 减速电机技术参数 Gear Motor Technical Data

减速比 Reduction ratio		4	10	21	34	47	78	103	130	227	499
6.0V	空载转速 No-load speed (rpm)	1200	480	240	145	105	60	48	37	21	10
	负载转速 Rated speed (rpm)	1050	420	210	120	90	55	40	32	19	8
	负载力矩 Rated torque (kg.cm)	0.04	0.08	0.15	0.24	0.3	0.5	0.6	0.8	1.1	2.5
	空载转速 No-load speed (rpm)	1600	650	320	190	140	85	65	50	30	13
12.0V	负载转速 Rated speed (rpm)	1450	580	270	170	120	75	55	45	25	12
	负载力矩 Rated torque (kg.cm)	0.08	0.16	0.3	0.5	0.6	0.9	1.2	1.5	2.2	3.0

## 单电机技术参数 Motor Technical Data

电机型号 Motor model	额定电压 Rated voltage VDC	无负荷 No-load		额定 Rated			堵转 Stall		
		转速 Speed r/min	电流 Current mA	转速 Speed r/min	力矩 Torque g.cm	电流 Current mA	功率 Power W	力矩 Torque g.cm	电流 Current A
TRK-320SH-13330	6.0	5000	50	4200	10	150	0.43	63	0.7
TRK-320SD-11425	12.0	6800	50	5800	20	180	1.19	136	0.8

