

# GM14-050SH

14mm gearbox plus 050 permanent magnet DC motor

模数 Module	0.15/0.2	
额定负载 Rated torque (kg.cm)	1.0 kg.cm max	
瞬间允许力矩 Max momentary tolerance torque (kg.cm)	2.0 kg.cm max	
减速比 Reduction ratio	1/30、1/63	1/115、1/130 1/250、1/300 1/350
齿轮箱减速级数 Number of gear stages	4	5
减速箱长度 Gearbox length L (mm)	12.0	

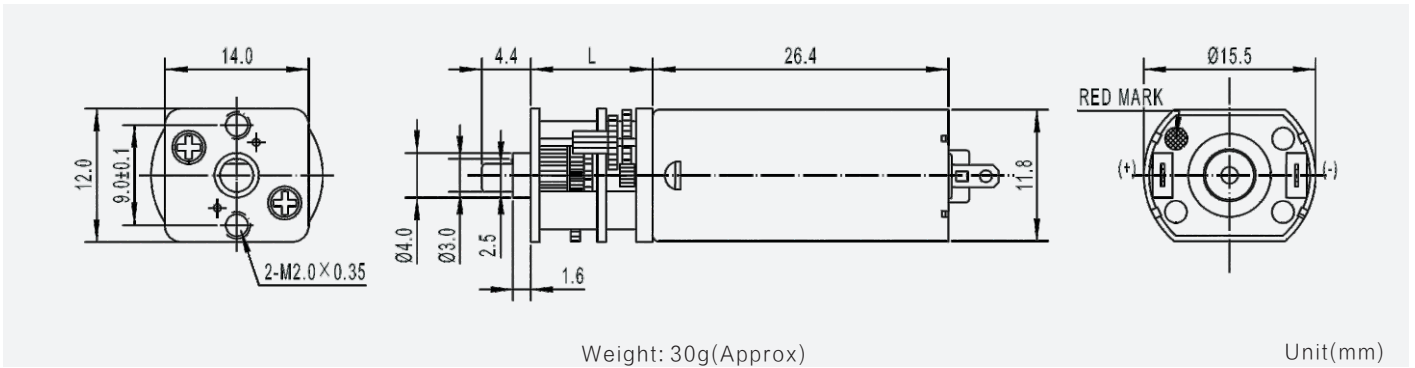

## 减速电机技术参数 Gear Motor Technical Data

电压 Voltage	减速比 Reduction ratio	性能 Performance						
		空载转速 No-load speed (rpm)	负载转速 Rated speed (rpm)	负载力矩 Rated torque (kg.cm)	空载转速 No-load speed (rpm)	负载转速 Rated speed (rpm)	负载力矩 Rated torque (kg.cm)	
6.0V	30	340	285	0.22	410	305	0.22	
	63	190	158	0.44	200	150	0.44	
	115	105	92	0.6	110	80	0.6	
12.0V	130	95	78	0.8	98	73	0.8	
	150	80	66	0.9	85	63	0.9	
	250	50	42	1.0	50	40	1.0	
	350	35	31	1.0	35	28	1.0	

## 单电机技术参数 Motor Technical Data

电机型号 Motor model	额定电压 Rated voltage	无负荷 No-load		额定 Rated			堵转 Stall		
		转速 Speed	电流 Current	转速 Speed	力矩 Torque	电流 Current	力矩 Torque	电流 Current	
	VDC	r/min	mA	r/min	g.cm	mA	W	g.cm	A
TFF-050SH-13120	6.0	12500	45	10000	10	255	1.03	50	1.30
TFF-050SH-08240	12.0	12800	35	9700	10	150	0.99	41	0.55

