

# GM13-050SH

13mm gearbox plus 050 permanent magnet DC motor

模数 Module	0.15		
额定负载 Rated torque (kg.cm)	0.5 kg.cm max		
瞬间允许力矩 Max momentary tolerance torque (kg.cm)	1.0 kg.cm max		
减速比 Reduction ratio	1/10	1/20, 1/35 1/63, 1/86	1/115, 1/150 1/250, 1/360
齿轮箱减速级数 Number of gear stages	2	4	5
减速箱长度 Gearbox length L (mm)	11.0		

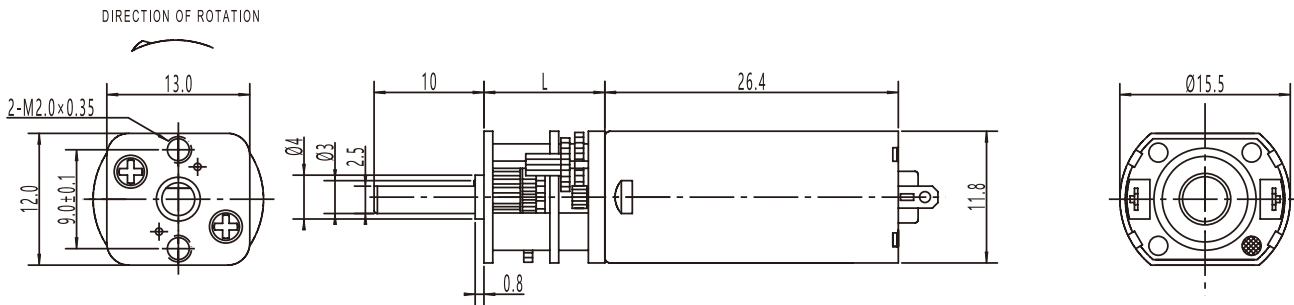

Weight: 22g(Approx)

Unit(mm)

减速电机技术参数 Gear Motor Technical Data		3	10	20	35	63	86	115	150	250	360
6.0V	减速比 Reduction ratio	3	10	20	35	63	86	115	150	250	360
	空载转速 No-load speed (rpm)	4000	1200	600	340	190	140	105	80	50	35
	负载转速 Rated speed (rpm)	3300	1000	500	285	158	116	92	73	46	33
12.0V	空载转速 No-load speed (rpm)	4100	1230	620	350	200	145	110	85	50	36
	负载转速 Rated speed (rpm)	3150	950	475	270	150	110	82	73	46	33
	负载力矩 Rated torque (kg.cm)	0.02	0.08	0.14	0.25	0.44	0.5	0.5	0.5	0.5	0.5

单电机技术参数 Motor Technical Data		无负荷 No-load		额定 Rated				堵转 Stall	
电机型号 Motor model	额定电压 Rated voltage	转速 Speed	电流 Current	转速 Speed	力矩 Torque	电流 Current	功率 Power	力矩 Torque	电流 Current
	VDC	r/min	mA	r/min	g.cm	mA	W	g.cm	A
TFF-050SH-13120	6.0	12500	45	10000	10	255	1.03	50	1.30
TFF-050SH-08240	12.0	12800	35	9700	10	150	0.99	41	0.55

