

GM12-N30VA

12mm gearbox plus N30 permanent magnet DC motor

模数 Module	0.15			
额定负载 Rated torque (kg.cm)	0.5 kg.cm max			
瞬间允许力矩 Max momentary tolerance torque (kg.cm)	1.0 kg.cm max			
减速比 Reduction ratio	1/10	1/20、1/30 1/50、1/63 1/100	1/110、1/150 1/210、1/250 1/298、1/380	1/1000
齿轮箱减速级数 Number of gear stages	2	4	5	7
减速箱长度 Gearbox length L (mm)	9.0		12.0	

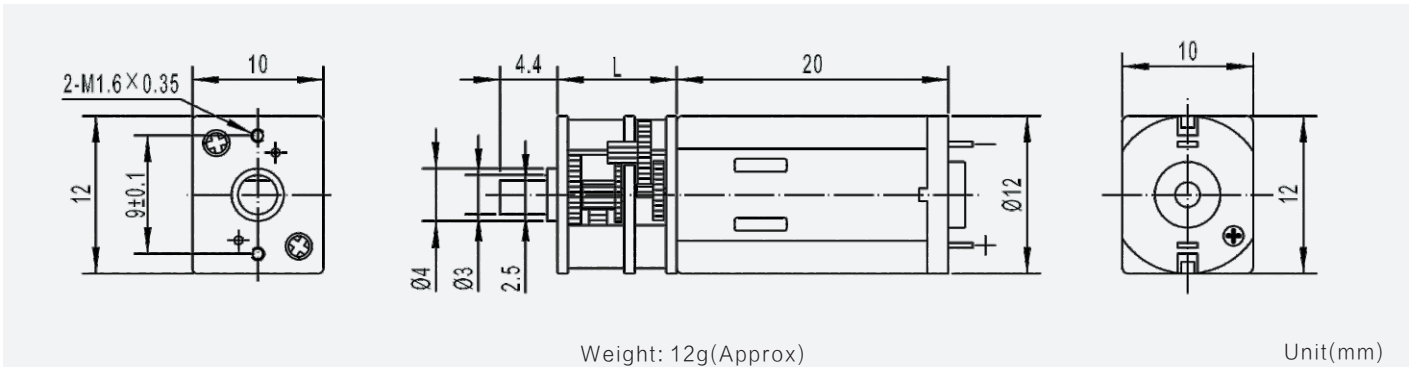

减速电机技术参数 Gear Motor Technical Data

减速比 Reduction ratio		10	30	50	100	150	210	250	298	380	1000
6.0V	空载转速 No-load speed (rpm)	1200	410	245	120	82	60	50	42	33	12
	负载转速 Rated speed (rpm)	1070	355	210	105	70	50	42	36	28	10
	负载力矩 Rated torque (kg.cm)	0.024	0.06	0.09	0.18	0.25	0.35	0.38	0.45	0.5	0.5
12.0V	空载转速 No-load speed (rpm)	1200	410	245	120	82	60	50	42	33	12
	负载转速 Rated speed (rpm)	1040	345	205	102	68	49	41	35	27	10
	负载力矩 Rated torque (kg.cm)	0.024	0.06	0.09	0.18	0.25	0.35	0.38	0.45	0.5	0.5

单电机技术参数 Motor Technical Data

电机型号 Motor model	额定电压 Rated voltage	无负荷 No-load		额定 Rated			堵转 Stall		
		转速 Speed	电流 Current	转速 Speed	力矩 Torque	电流 Current	功率 Power	力矩 Torque	电流 Current
	VDC	r/min	mA	r/min	g.cm	mA	W	g.cm	A
TFF-N30VA-09190	6.0	12500	25	10600	3.0	98	0.33	20	0.50
TFF-N30VA-06350	12.0	12500	12	10400	3.0	50	0.32	18	0.25

